

**EagleBurgmann®**

Rely on excellence

# Competence in compressor sealing



# EagleBurgmann at the forefront of technology: Milestones in innovative product development.

2009

**The world's largest and "hottest" gas seal (+250 °C / +482 °F) - an EagleBurgmann PDGS - is brought into service in China.**

2014

**Established technology: compressors on over 45 LNG tankers and more than 35 oil platforms are sealed with EagleBurgmann gas seals.**

2012

**Dry gas seals can now be used to pump water/oil/gas mixtures: EagleBurgmann DF-(P)DGS6 seals with DiamondFace bonding are brought into practice in multiphase pumps.**

1999

**EagleBurgmann develops the first gas seal for low-temperature applications (-170 °C / -274 °F) for market launch. These are used, in particular, in compressors and companders on LNG carriers.**

1992

**EagleBurgmann introduces the first DLC-coated (Diamond-Like Carbon) silicon carbide seal faces into practical use, achieving excellent wear-resistance in the low-speed range.**

1989

**EagleBurgmann presents the first bi-directional gas seal, opening up new dimensions in the use of gas-lubricated mechanical seals.**

## Important note

All the technical specifications are based on extensive tests and our many years of experience. However, the diversity of possible applications means that they can serve as guide values only.

It should be noted that the extremal values of each operating parameter cannot be applied at the same time because of their interaction. Furthermore, the operating range of each specific product depends on the respective shaft diameter, materials used, mode of operation and on the medium to be sealed.

A guarantee can only be given in the individual case if the exact conditions of application are known and these are confirmed in a special agreement. When critical conditions of operation are involved, we recommend consulting with our specialist engineers.

Subject to change.



2010

**EagleBurgmann launches the first diamond-coated seal faces for gas seals. The EagleBurgmann DiamondFace technology is used successfully for applications in critical operating modes.**

1988

**EagleBurgmann develops the characteristic three-dimensional V-grooves. This solution provides the best lift-off properties, even at low speeds and optimum gas film stiffness, for safe operation.**

2009

**EagleBurgmann launches the innovative RoTechBooster - the first booster system for supplying pure gas continuously and reliably to compressor seals.**

2008

**With the coaxial gas-lubricated CobaSeal, EagleBurgmann revolutionizes the use of separation seals for compressors and outstrips all existing systems on the market with respect to leak prevention.**

## The sealing specialist

EagleBurgmann is one of the leading system suppliers of sealing technology for compressors. We have used our innovative approach to shape this high-tech sector for gas-lubricated mechanical seals since the early 80s.

We offer our customers – OEM, EPC and end users – a technically mature and well-established portfolio of rugged standard gas seals with appropriate gas supply systems. This is combined with engineered solutions designed for specific applications and a long-term global service concept. Decades of experience, outstanding design and calculation expertise and state-of-the-art, top quality production make us stand out to our customers. This is reflected in longer operating periods and MTBF, greater process safety and increased availability for both compressor and plant.

## High-end sealing technology

EagleBurgmann gas seals are used in all types of compressors to seal the shaft. Applications include compressors for oil and gas processes, pipelines, refinery equipment and the petrochemical and chemical industries. The demands that manufacturers, operators and the environment make in terms of safety, sealing and robustness are challenging. The EagleBurgmann solutions are not only technically safe, but they are also highly cost-effective.

Dry Gas Seals in all arrangements (single, double, tandem and tandem with intermediate labyrinth), aerostatic and aerodynamic separation seals, custom-designed seal management and booster systems to ensure a continuous gas supply - with EagleBurgmann you will receive everything from a single source. Without compromise.

## Full service partner

Research and development, consulting, engineering, design, production and a broad range of modular services are competencies that our customers demonstrably use to their benefit. Our comprehensive network of special centers of competence around the world supports our customers with assembly, overhaul, repair and acceptance testing services.

# Experience, demand and commitment: The building blocks for optimized sealing solutions.

## Reliable market partner with worldwide presence

With over 60 subsidiaries and 250 locations worldwide, we use our global focus to the benefit of our customers. Thus our production network, which has plants in Europe, Asia, North and South America, ensures that we are always in line with market requirements and that we can produce on attractive terms and are able to supply regional markets.

We also have a comprehensive network of sales and service centers which covers every important economic region. Being close to our customers also means we are precisely acquainted with their processes and individual requirements.

EagleBurgmann is part of the German Freudenberg Group and the Japanese EKK Group. We have access to all the resources we need to offer optimum support to major customers at the international level and also become their long-term, reliable partner.

## Consulting and engineering with meaning

Technical expertise grows from knowledge. This does not only have to mean knowledge of sealing technology, it also takes into account the compressors, plants and systems used and the industrial processes and process conditions.

Knowledge management helps us keep our comprehensive knowledge up to date and make it available to the entire company. We use databases, courses and training to develop our employees and bundle our expert knowledge from all around the world.

Our dedicated and committed employees use this wide and varied know-how to give our customers well-founded advice on how to choose the best sealing solution from the technical and economic viewpoints and how to calculate and design according to need.

## High-level research and development

We invest a great deal in research and development in order to consistently improve the performance of our products. EagleBurgmann carries out publicly sponsored research projects and works together with institutes and universities. Joint projects with customers and suppliers are a regular source of new solutions.

Two large research and development centers in Germany and Japan, combined with a worldwide network of testing facilities, allow us to respond flexibly to the requirements of our customers.



### **Broad standard product portfolio and custom solutions**

Largely standardized and modular product series are an essential part of our gas seal portfolio. But we also offer individual solutions and provide the necessary development, engineering and production capacity. Using the latest calculation and design methods, such as 3D-CAD, we adapt our products to customer-specific requirements or design new solutions.

EagleBurgmann produces to the most exacting internal and external standards. We use ultra-modern equipment, optimized and standardized production processes and a great vertical production range – all building upon the reliable base of our excellent employees. Our quality management systems are ISO 9001 certified, for example.

### **Protection of humans, the environment and industrial plants**

Safety is an elementary requirement for industrial sealing technology. It is ultimately all about protecting people, the environment, products and resources. A lot of what EagleBurgmann does goes far beyond the legal requirements. This sense of responsibility is part of the company culture and is firmly anchored in the guiding principles of the group.

Our environmental management system is ISO 14001 certified and our work safety management system fulfils OHSAS 18001. Regular audits and numerous training courses raise awareness in employees and management alike. This develops a culture in which everyone feels responsible for work safety, the environment and health protection within the company and on our customers' own premises.

### **Modular service concept ensures maximum flexibility**

Products and services are two sides of the same coin. Professional installation and commissioning, practical knowledge transfer, intelligent inventory management and regular servicing and maintenance extend service life and protect investments.

The need for services varies according to the operator and the system and is as diverse as the industry itself. Failure mode analysis, tailored onsite services and engineering services related to sealing technology play an important role.

Be it for individual sealing systems, critical process elements, specific plant units or a comprehensive service agreement for entire plants - our TotalSealCare modular service concept has the solution for every requirement. The individual service modules can be combined as needed to ensure maximum flexibility.



# Lifted-off, non-contacting and efficient: This is how gases are sealed.

## Key sealing components

Reliable sealing of the process gas plays an important role when running compressors. Different system components are used depending on the medium, operating conditions, type of construction and how it is operated.

- **Main seal** (e.g. DGS, PDGS): Seals the shaft from the bearing side. Available as a single, double, tandem or tandem seal with intermediate labyrinth.
- **Separation seal** (e.g. CSR, CSE, CobraSeal): Seals the bearing oil in the compressor drive from the sealed space. Available as non-contacting or lift-off carbon ring seals and as aerostatic lift-off gas-lubricated seals.
- **Seal management system** (e.g. SMS): Supplies the main and separation seals with separation, seal or buffer gas and monitors the sealing system for health of the seal.
- **Booster system** (e.g. RoTechBooster): Continuous gas supply when compressor is operating slowly or is stopped.

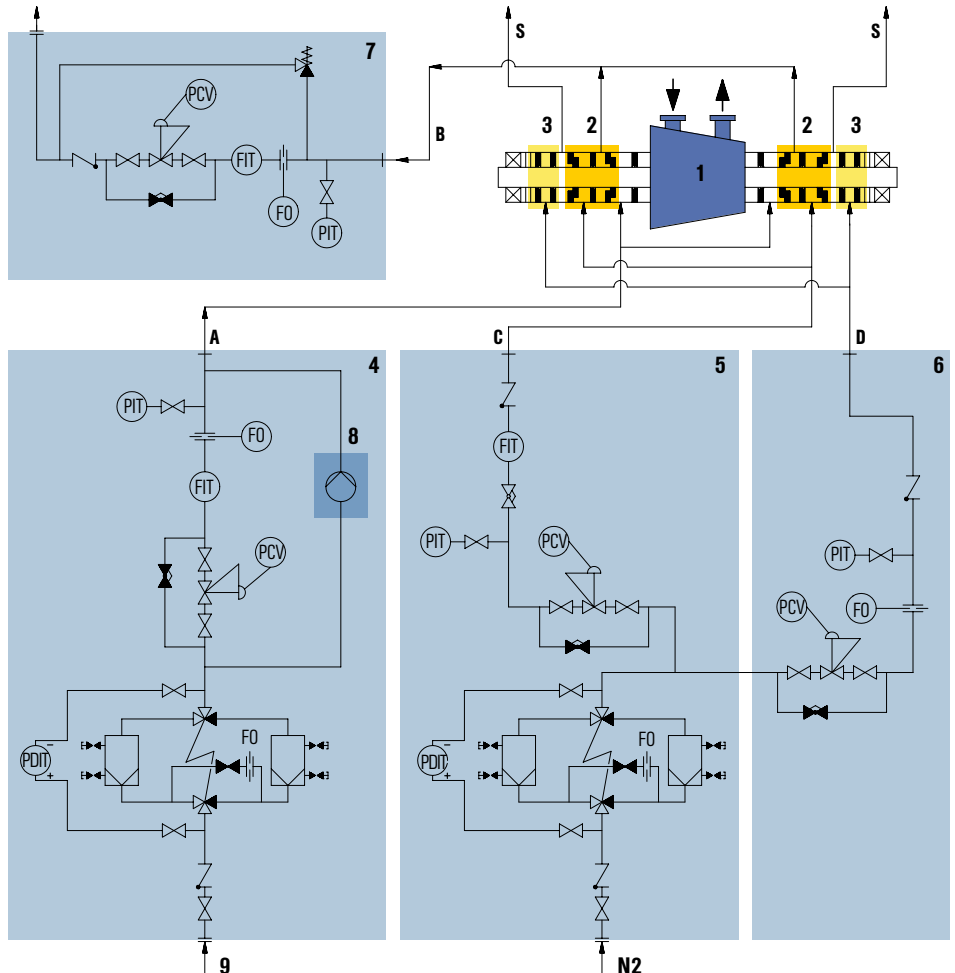

### Item Description

- |   |   |
|---|---|
| 1 | Compressor                                |
| 2 | Dry Gas Seal                              |
| 3 | Separation seal                           |
| 4 | Primary seal gas line or buffer gas line  |
| 5 | Secondary seal gas line                   |
| 6 | Separation gas line                       |
| 7 | (Primary) vent line                       |
| 8 | RoTechBooster module                      |
| 9 | Gas conditioning skid connection (option) |

- |   |                            |
|---|----------------------------|
| A | Primary seal gas supply    |
| B | Primary vent               |
| C | Secondary seal gas supply  |
| S | Secondary vent             |
| D | Separation seal gas supply |

## How gas-lubricated mechanical seals work

### Uni-directional V-groove

Gas enters into the three-dimensional V-grooves and between the seal faces by rotation. Due to shear of the gas, pressure increases and a stable gas film establishes. This results in lift-off of the seal faces and allows non-contacting running. The sealing gap is just a few micrometers, so any leakage flows are minimal. The sloping base of the groove creates an effective self-cleaning effect.

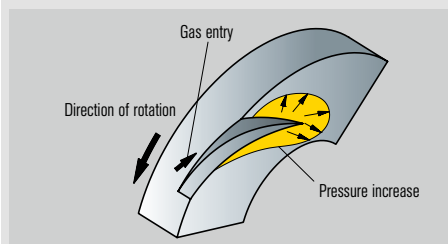

### Bi-directional U-groove

The U-groove works in the same way as the V-groove, with the difference that the U-groove is bi-directional. The shape of the groove is again three-dimensional. The gas entry occurs in the middle of the groove and builds up pressure and a gas film against the direction of rotation.

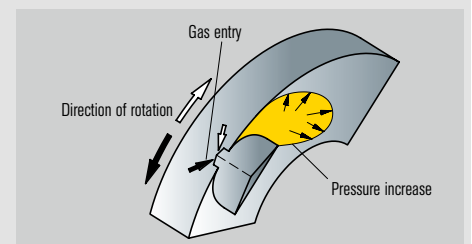

## Basic arrangements

Four seal arrangements are used according to the application and type of machine: single seal, double seal, tandem seal and tandem seal with intermediate labyrinth. Each arrangement may be optionally equipped on the bearing side with a labyrinth, aerodynamic (CSR) or aerostatic (CSE) carbon rings or a coaxial CobaSeal.

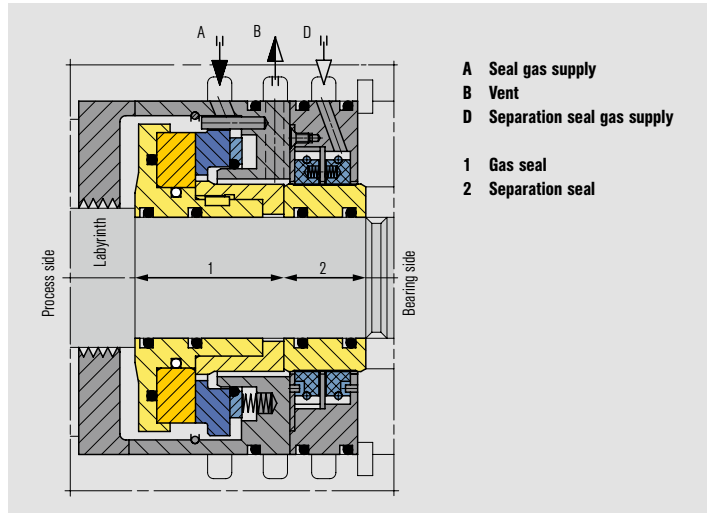

### Single seal

Application: where leakage of the product into the atmosphere is not harmful, e.g. from air or nitrogen compressors or the axial cavity does not allow a tandem seal (e.g. geared compressors). This version allows process gas leakage to the corresponding flare / vent connection. Primary seal leakage is dissipated with the separation gas to the vent. The gas to be sealed must also be filtered and routed to the seal chamber via connection "A". The resulting flow from the sealed space to the impeller side prevents contaminated / wet gas reaching the Dry Gas Seal on the process gas side, e.g. towards the labyrinth.

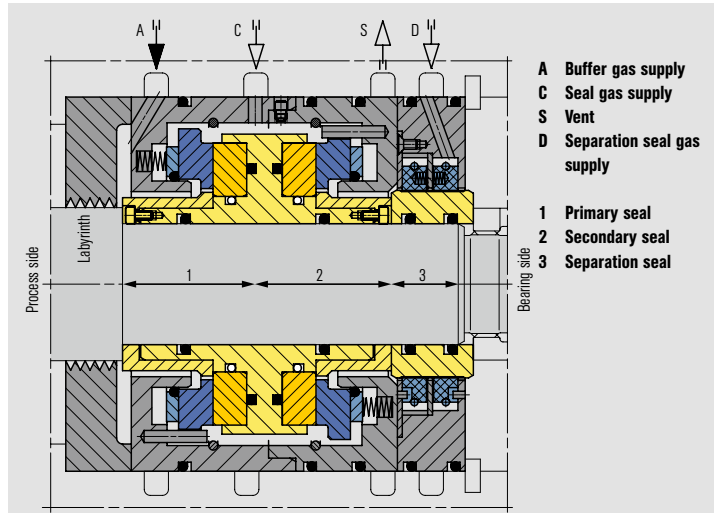

### Double seal

Application: where product leakage to the atmosphere/flare is unacceptable or for low pressure applications. Seal gas leakage into the product needs to be permitted (seal gas pressure  $p_3 > p_1$ ). This is used when a neutral seal gas is available at the appropriate pressure. Typical applications can be found in the chemical and petrochemical industries, e.g. in HC gas compressors. A seal gas, e.g. nitrogen at a pressure higher than the product pressure, is supplied between the seals via connection "C". Part of the seal gas leakage dissipates to the bearing side, while the other part goes to the product.

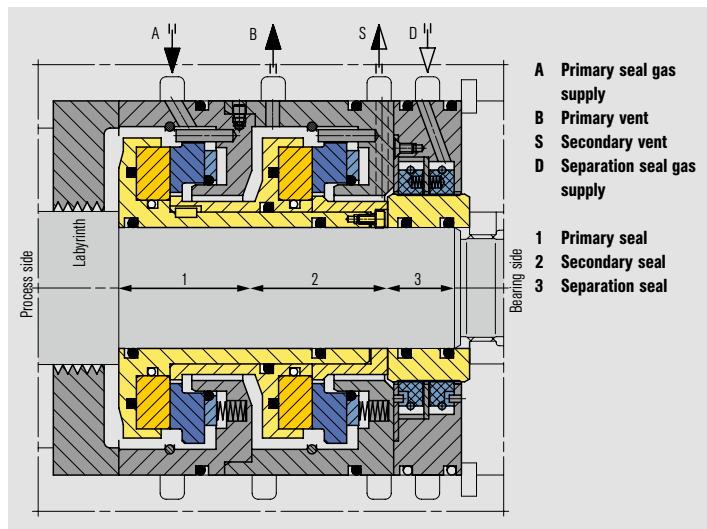

### Tandem seal

Application: where no  $N_2$  is available and minimal process gas leakage to the atmosphere is acceptable, e.g. gas pipeline compressors. The seal on the bearing side is intended as a safety seal. The tandem arrangement offers particularly good operational safety. The process side and bearing side seals are able to withstand the full pressure. In normal operation, only the process side seal reduces the full pressure. The space between the process side and bearing side seals is routed to the flare via connection "B". The pressure to be sealed on the bearing side corresponds to the flare pressure. There is thus very little leakage to the bearing side or to the vent. If the primary seal fails, the secondary seal is activated as a back-up and operates at primary seal conditions.

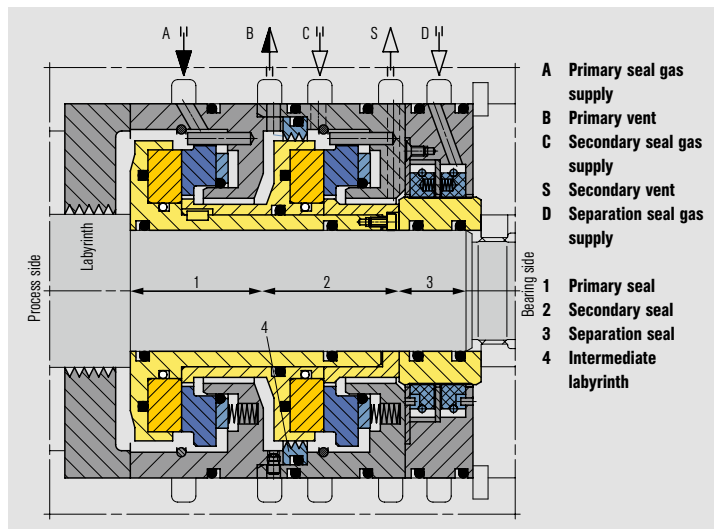

### Tandem seal with intermediate labyrinth

Application: where product leakage to the atmosphere is unacceptable, e.g.  $H_2$ , ethylene or propylene compressors. With this type of seal, the product pressure to be sealed is reduced via the seal on the process side. The entire process gas leakage is routed to the flare via connection "B". The bearing side seal is pressurized with secondary seal gas (nitrogen) via connection "C". The pressure of the secondary seal gas ensures the flow through the labyrinth to the flare/ tapping point.

## Face materials and seal face finish technology

EagleBurgmann uses mainly silicon carbide (SiC) against silicon carbide as the sliding material pairing. For specific applications (e.g. CO) carbon graphite is optionally used for stationary seal faces. These combinations are extremely robust and durable and have proven their worth in thousands of standard, high pressure and high speed applications.

Dry gas seals must never run in contact mode at moderate to high sliding speeds. However, contact operation does occur during start/stop, and might occur for a certain time in coast-down and turning operation. To avoid any damage in temporary low speed contact operation, the seal faces need to be protected.

To ensure a long service life and to allow seals to run under extreme conditions, EagleBurgmann offers three different seal face finishes according to the application and design of the seal: DiamondFace, Diamond-Like Carbon (DLC) and titanium nitride (DM-TiN). Each of these coatings has its own strengths to suit specific requirements.



Video: DiamondFace

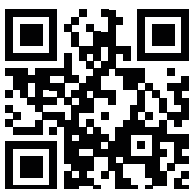

## DLC (Diamond-Like Carbon)

This hydrogenated amorphous carbon coating (a-C:H), applied by plasma enhanced chemical vapour deposition (PECVD), features excellent wear protection and friction reduction for silicon carbide seal faces. The high hardness and the specially designed surface offer great protection against scoring. DLC is used as standard coating for silicon carbide seal faces and is only surpassed by the extraordinary properties of the DiamondFace coating. In terms of material properties, the a-C:H DLC coating is to classify between diamond and carbon graphite.

## DM-TiN titanium nitride

The DM-TiN titanium nitride coating applied by dynamic ion beam mixing (standard: 1.4006/SU410, Japanese pat. no. 2134661) has excellent microhardness and adhesion properties as it penetrates into the metal, bonding with it extremely well. Titanium nitride coatings are used to protect the metal seal faces of compressor seals (e.g. MDGS) against scoring. DM titanium nitride/carbon graphite pairings have a favorable friction coefficient and extremely good emergency running properties.

## DiamondFace

In 2007, EagleBurgmann created a landmark in mechanical seal technology with the introduction of DiamondFace. A microcrystalline coating with all the attributes of natural diamond is applied to the seal faces by chemical vapor deposition (CVD) at 2,000 °C (3,632 °F) in a vacuum reactor. Thick coating coupled with extremely flat and uniform seal faces characterize this procedure, which was developed together with the Fraunhofer Institute for Surface Engineering and Thin Films in Braunschweig, Germany. The coating adhesion exceeds all known practical requirements.

Seal faces with DiamondFace offer excellent thermal conductivity, are extremely hard and resistant to wear and exhibit low friction and highest chemical resistance. For compressor seals, the service life is multiplied several times for critical applications, the maintenance intervals are extended accordingly and the life cycle costs can be greatly reduced.

## Design and calculation

EagleBurgmann compressor seals consist of two structural modules: The standardized inner parts of the seal (core parts) and the adaptive parts, which are individually matched to the installation location (housing, shaft sleeves, connecting parts, etc.). This system enables us to optimally match customer requirements with the conditions of use.

Seal design and optimization requires a profound physical understanding of the seal behavior. Theoretical knowledge combined with most efficient computational analysis methods allow us to design highest-performance standard seals as well as very special seal designs adapted to particular customer's requirements. Whenever required, computational fluid dynamics methods (CFD) for flow field analysis and finite element methods (FEM) for structural analysis will be applied to investigate all necessary details of the inner seal environment such as stress, deflection and temperature distribution.



## Production and testing

High-tech production methods, state-of-the-art machines, maximum precision in all production processes and the best-trained employees are the keys to excellent and reproducible quality. EagleBurgmann compressor seals are produced in Germany (Eurasburg). The second production location is Japan (Niigata).

Right after production and assembly all dry gas and oil-lubricated compressor seals are going through a pass-off test on our test rigs. Realistic operating conditions, tight checking criteria and detailed documentation will ensure that every EagleBurgmann compressor seal leaves the plant at the highest level of operational reliability.





# EagleBurgmann compressor seals



**EagleBurgmann offers a fine-tuned portfolio of Dry Gas Seals that covers a wide range of applications.**

The following pages contain an overview of our main series. All seals are generally available in the commonly-used arrangements (single, double, tandem and tandem with intermediate labyrinth), with or without separation seal. You can also expect to find innovative technical and economical solutions, such as the combination of single seal with an separation seal or ultra-high pressure seals from the PDGS series for special applications.

**DGS standard seals**

**PDGS high pressure seals**

**MDGS for screw compressors**

**TDGS for steam turbines**

**NF941 for special applications**

**WRS oil-lubricated compressor seals**

**EBU800 oil-lubricated compressor seals**

These are well-established and rugged sealing concepts for many different applications in screw compressors but are also suitable for centrifugal compressors. They are used, for example, in closed process circuits from which as little gas as possible should be allowed to leak, but where a slight oil leakage into the process can be tolerated.

## DGS

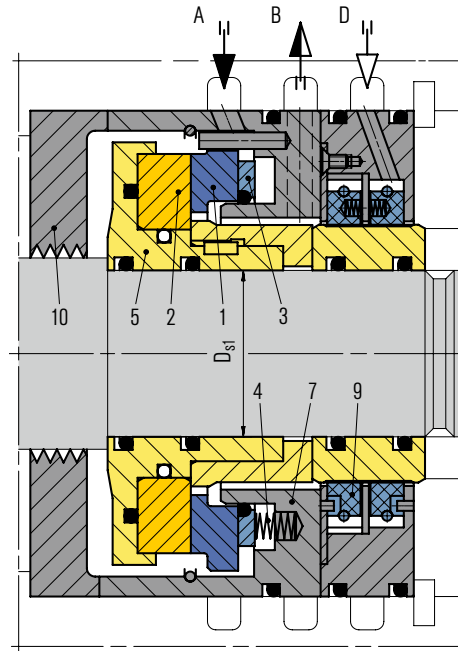

DGS single seal with a CSR separation seal. This highly compact sealing system is typically used in geared compressors.

Seals from the DGS series are the standard for medium pressures up to 120 bar (1,740 PSI). They have proven their suitability in thousands of applications worldwide. They are very rugged with a mature design concept. The advantage over the competition is hidden in the detail. For example, the torque is transmitted to the rotating seat by friction forces only. And thus no holes and resulting weakening of the material are needed.

#### Features

- Gas-lubricated
- Uni-directional or bi-directional
- Ready-to-fit cartridge unit
- Single, double, tandem seal and tandem with intermediate labyrinth available
- Separation seals as labyrinths, radial clearance seals or CobraSeal are optionally available

#### Advantages

- Wear-free and contact-free operation
- Self-cleaning 3D gas grooves
- High gas film stiffness
- Secure cupped retainer for seat
- Available in various materials for optimized chemical resistance
- Proven, reliable and economical solution

#### Operating range

Shaft diameter:  $D_{s1} = 29 \dots 264 \text{ mm (1.14" ... 10.39")}$   
 Pressure:  $p = 0 \dots 120 \text{ bar (1,740 PSI)}$   
 Temperature:  $t = -20 \text{ °C ... } +200 \text{ °C (-4 °F ... } +392 \text{ °F)}$   
 Sliding velocity:  $v_g = 0.6 \dots 200 \text{ m/s (2 ... 656 ft/s)}$

#### Materials

Seal face: Silicon carbide with DLC coating  
 Seat: Silicon carbide with DLC coating  
 Secondary seals: FKM  
 Metal parts: 1.4006 or other stainless steels  
 Available also with EagleBurgmann DiamondFace technology. For more information see page 8.  
 Other materials on request.

#### Certificates

- NACE

#### Item Description

1	Seal face, stationary
2	Seat, rotating
3	Thrust ring
4	Spring
5	Shaft sleeve and seat retainer
7	Housing (size matched to installation space)
9	Carbon ring separation seal CSR
10	Labyrinth
A	Seal gas supply
B	Vent
D	Separation gas supply

# PDGS

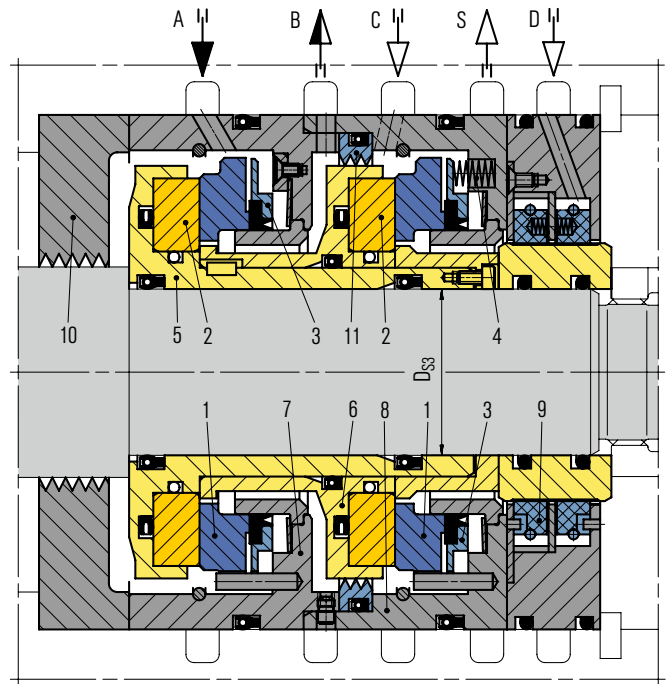
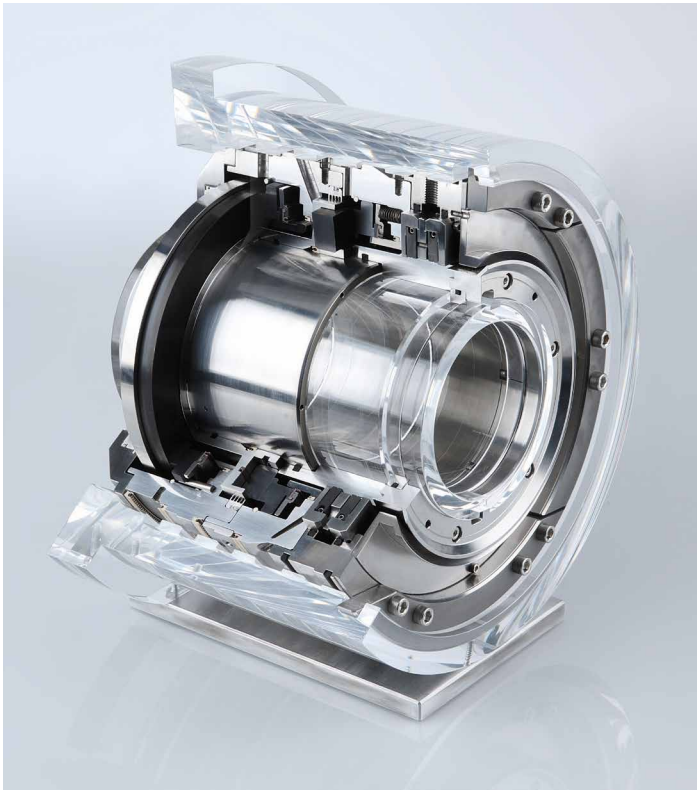

**PDGS tandem seal with intermediate labyrinth and CSR separation seal for ultra-high pressure applications. This type is used, for example, in compressors for gas reinjection in offshore applications.**

A well-established compressor seal for high pressure and both low and high temperature applications. Innovative design features allow it to cope with even the highest pressures without problems. The application of U-cups and special dynamic sealing elements opens up a wide range of uses for this versatile and successful seal series.

### Features

- Gas-lubricated
- Uni-directional or bi-directional
- Elastomer-free
- Ready-to-fit cartridge unit
- Single, double, tandem seal and tandem with intermediate labyrinth available
- Separation seals as labyrinths, radial clearance seals or CobraSeal are optionally available

### Advantages

- Wear-free and contact-free operation
- Self-cleaning 3D gas grooves
- High gas film stiffness
- Secure cupped retainer for seat
- Available in various materials for optimized chemical resistance
- Proven, reliable and economical solution

### Operating range

Shaft diameter:  $D_{s3} = 29 \dots 355 \text{ mm} (1.14" \dots 13.98")$   
 Pressure:  $p = 0 \dots 450 \text{ bar} (0 \dots 6,525 \text{ PSI})$   
 Temperature:  $t = -170 \text{ °C} \dots +230 \text{ °C}$   
 (-274 °F ... +446 °F)  
 Sliding velocity:  $v_g = 0.6 \dots 200 \text{ m/s} (2 \dots 656 \text{ ft/s})$

### Materials

Seal face: Silicon carbide with DLC coating  
 Seat: Silicon carbide with DLC coating  
 Secondary seals: Polymer rings  
 Metal parts: 1.4006 or other stainless steels  
 Available also with EagleBurgmann DiamondFace technology. For more information see page 8.  
 Other materials on request.

### Certificates

- NACE

### Item Description

- |    |  |
|----|--|
| 1  | Seal face, stationary                        |
| 2  | Seat, rotating                               |
| 3  | Thrust ring                                  |
| 4  | Spring                                       |
| 5  | Shaft sleeve and seat retainer               |
| 6  | Intermediate sleeve                          |
| 7  | Housing (size matched to installation space) |
| 9  | Carbon ring separation seal (CSR)            |
| 10 | Labyrinth                                    |
| 11 | Intermediate labyrinth                       |
| A  | Primary seal gas supply                      |
| B  | Primary vent                                 |
| C  | Secondary seal gas supply                    |
| S  | Secondary vent                               |
| D  | Separation gas supply                        |

# MDGS

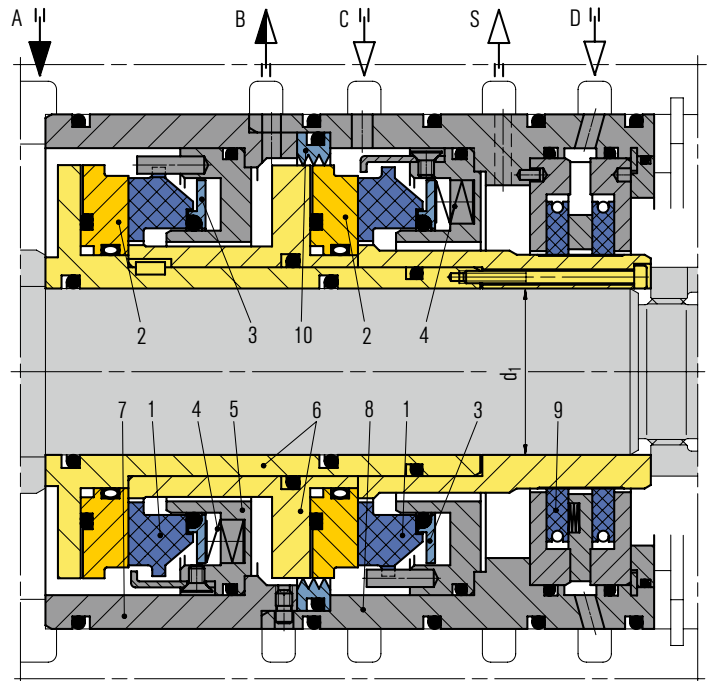

**MDGS design example: Tandem seal with intermediate labyrinth.** A typical solution used in combustible, toxic and environmentally harmful gases. The separation seal is an EagleBurgmann type CSE non-contacting carbon segment seal.

EagleBurgmann MDGS are rugged seals for screw compressors. They have a rotating ring made from ductile material with a high-performance coating. Rotating rings are "in-situ shrouded", making them practically indestructible. The coating offers excellent wear resistance in the low speed range (e.g. coast-down operation) in which contact between the seal faces is unavoidable.

The stationary, spring-mounted system is optionally available as a sub-cartridge in combination with a rotating seat made from ductile material. A secondary sealing function using O-rings allows it to be applied as a component seal.

### Features

- Gas-lubricated
- Bi-directional
- Compact, radial design
- Ready-to-fit cartridge unit, also available as a component seal
- Single, double, tandem seal and tandem with intermediate labyrinth available

### Advantages

- Wear-free and contact-free operation
- Self-cleaning 3D gas grooves
- High gas film stiffness
- Fits into small spaces (e.g. process gas screw compressors)
- Available in various materials for optimized chemical resistance
- Proven, reliable and economical solution

### Operating range

Shaft diameter:  $d_1 = 48 \dots 200 \text{ mm}$  (1.89" ... 7.87")  
 Pressure:  $p = 0 \dots 50 \text{ bar}$  (0 ... 725 PSI)  
 Temperature:  $t = -20 \text{ }^\circ\text{C} \dots +200 \text{ }^\circ\text{C}$  (-4 °F ... +392 °F)  
 Sliding velocity:  $v_g = 0.6 \dots 200 \text{ m/s}$  (2 ... 656 ft/s)

### Materials

Seal face: Carbon graphite  
 Seat: Ductile stainless steel with DM-TiN coating  
 Secondary seals: FKM  
 Metal parts: 1.4006 or other stainless steels

### Certificates

- NACE

### Item Description

- |      |                                   |
|------|-----------------------------------|
| 1    | Seal face, stationary             |
| 2    | Seat, rotating                    |
| 3    | Thrust ring                       |
| 4    | Spring                            |
| 5    | Adapter                           |
| 6    | Shaft sleeve                      |
| 7, 8 | Housing                           |
| 9    | Carbon ring separation seal (CSE) |
| 10   | Labyrinth                         |

- |   |                         |
|---|-------------------------|
| A | Primary seal gas supply |
| B | Primary vent            |
| C | Secondary gas supply    |
| S | Secondary vent          |
| D | Separation gas supply   |

# TDGS

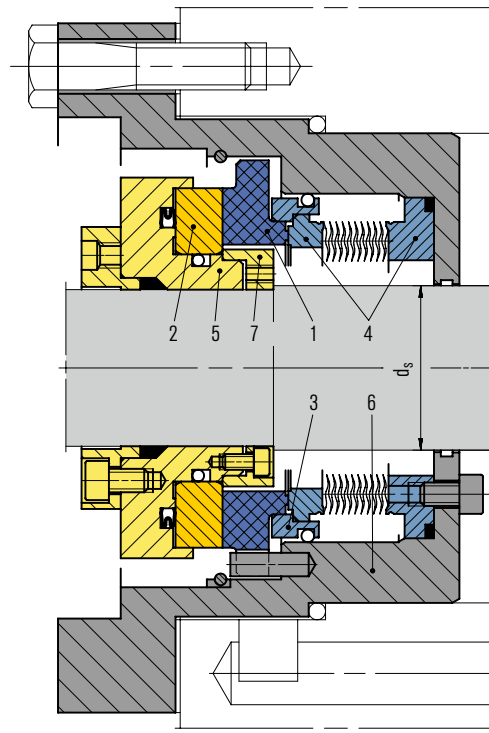
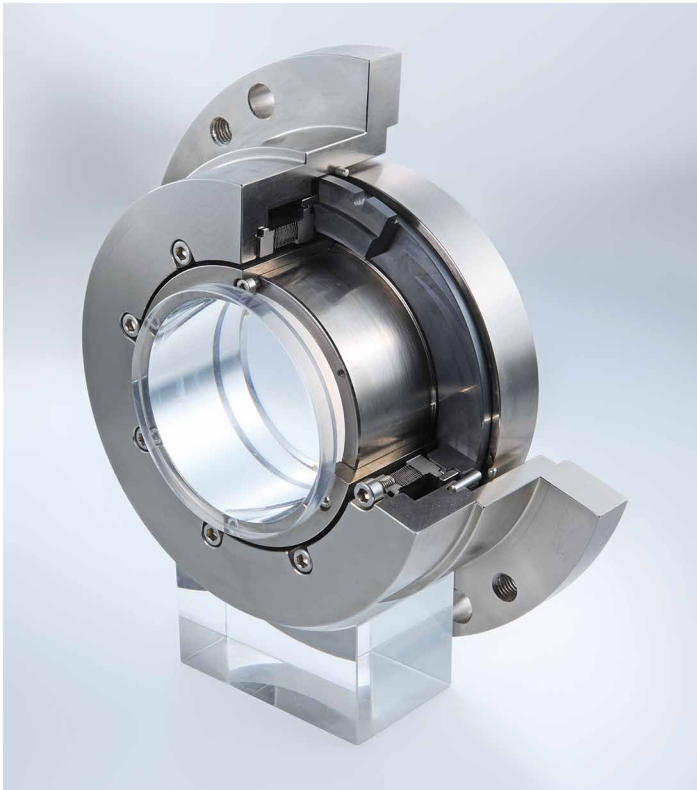

**TDGS single seal.**  
The typical design as used to seal condensing and back-pressure turbines.

The gas seal for single-stage steam turbines. A metal bellows allows it to work reliably even at high temperatures. Any steam leakage that does occur will be just a fraction of the leakage from carbon ring seals. This both saves energy and improves the performance of the turbine. The bearing oil is no longer contaminated by condensed steam, extending the bearing life and reducing maintenance costs accordingly.

## Features

- Gas-lubricated
- Uni-directional or bi-directional
- Elastomer-free, no dynamic O-ring
- Ready-to-fit cartridge unit
- Single seal available

## Advantages

- Wear-free and contact-free operation
- Self-cleaning 3D gas grooves
- High gas film stiffness
- Extremely low steam leakage
- Bearing oil not contaminated with condensed steam

## Operating range

Shaft diameter:  $d_s = 40 \dots 140 \text{ mm}$  (1.57" ... 5.51")

Pressure:  $p = 0 \dots 10 \text{ bar}$  (0 ... 145 PSI)

Temperature:  $t = -50 \text{ }^\circ\text{C} \dots +450 \text{ }^\circ\text{C}$  (-58 °F ... +842 °F)

Sliding velocity:  $v_g = 130 \text{ m/s}$  (427 ft/s)

## Materials

Seal face: Carbon graphite

Seat: Silicon carbide

## Certificates

- NACE

## Item Description

- | Item | Description                                  |
|------|--|
| 1    | Seal face, stationary                        |
| 2    | Seat, rotating                               |
| 3    | Sleeve                                       |
| 4    | Metal bellows cartridge unit                 |
| 5    | Shaft sleeve                                 |
| 6    | Housing (size matched to installation space) |
| 7    | Clamping ring                                |

# NF941

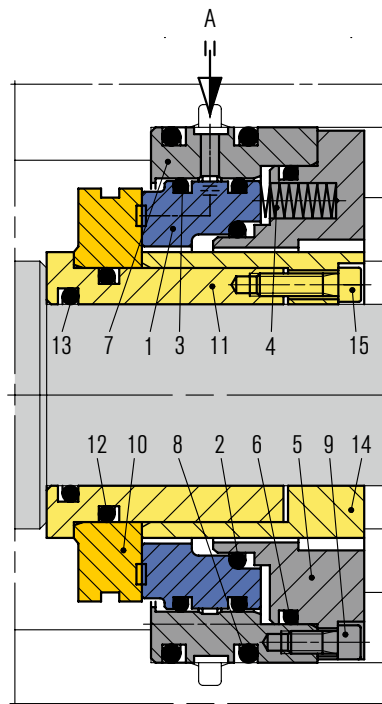
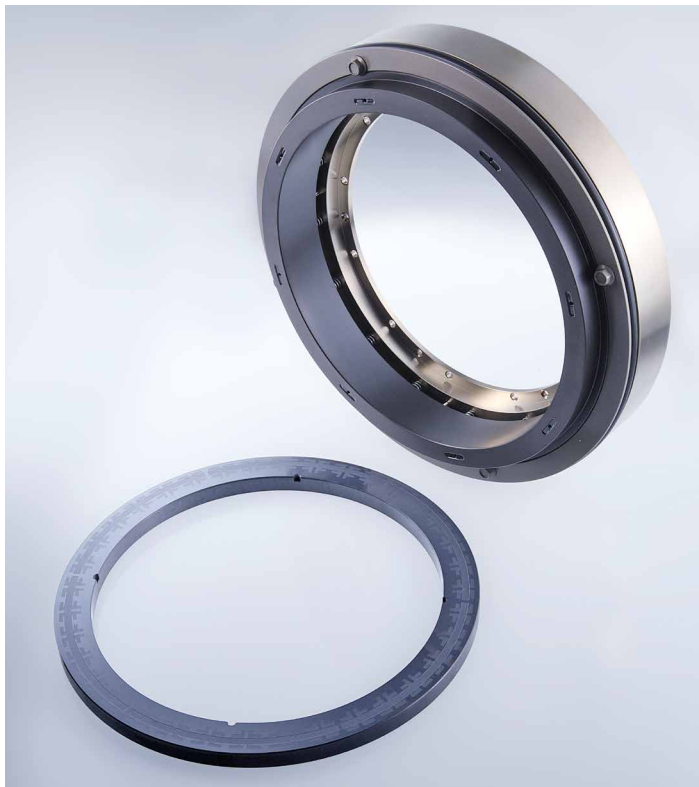

NF941 single seal. These are typically used in the semiconductor industry, for example, due to the extremely low leakage.

Seals from the NF941 series are used in screw compressors for special applications. They are hybrid seals that seal both aerostatically and aerodynamically. The separation gas is routed through holes in the stationary seal ring directly between the seal faces, while the lift-off is caused by specially designed gas grooves.

### Features

- Single seal with double seal function
- Non-contacting from static to high speed condition
- Balanced
- Bi-directional
- Stationary multiple springs

### Advantages

- Wear-free and contact-free operation
- Prevents the ingress of foreign particles

### Operating range

Pressure:  $p = 5 \text{ bar (73 PSI)}$   
 Temperature:  $t = -20 \text{ °C ... } +200 \text{ °C (-4 °F ... } +392 \text{ °F)}$   
 Sliding velocity:  $v_g = 60 \text{ m/s (197 ft/s)}$

### Materials

Seal face: High-density carbon graphite  
 Seat: Ductile stainless steel with TiN-coating or silicon carbide  
 Secondary seals: FKM  
 Metal parts: CrNiMo steel

### Item

### Description

1	Seal face
2, 3, 6, 8, 12, 13	O-ring
4	Spring
5	Adapter
7	Housing
9, 15	HSH cap screw
10	Seat
11	Shaft sleeve
14	Clamp sleeve
A	Seal gas supply

# WRS

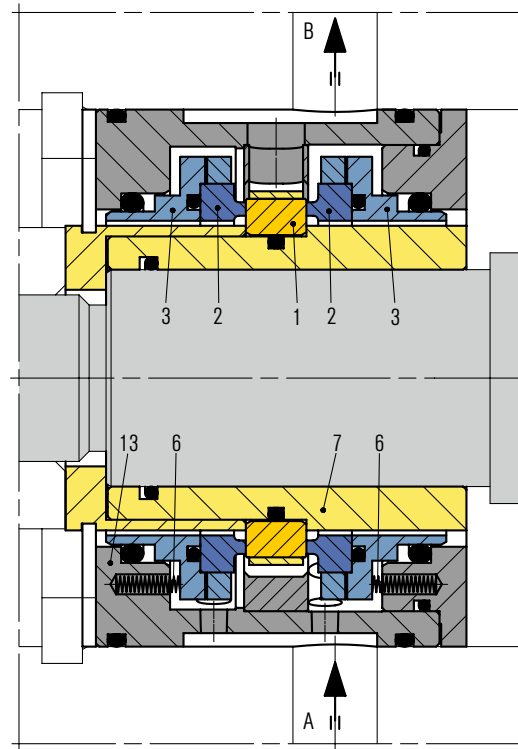

WRS double seal for use in refrigeration compressors and expansion turbines.

The WRS is an **oil-lubricated** seal that safely seals various types of compressors and organic media. With its rugged design, low life-cycle costs and long service life, the WRS can be found in thousands of applications. The design is optimized by using the finite element method and computational fluid dynamics.

## Features

- Oil-lubricated
- Bi-directional
- Externally pressurized
- Ready-to-fit cartridge unit
- Single, face bushing and double seal available
- Suitable for high speeds
- Hydrodynamic grooves for increased operating capabilities and stabilized low leakage

## Advantages

- Low oil consumption
- Rugged seat with bandage ensures reliable operation
- Wear-free operation by use of lift-off-design
- Does not open if oil pressure drops

## Operating range

Shaft diameter: 30 ... 300 mm (1.18" ... 11.81")

Pressure:  $p = \dots 50$  bar (725 PSI)

Gas temperature:  $t = -20$  °C ...  $+200$  °C (-4 °F ...  $+392$  °F)

Sliding velocity:  $v_g = 90$  m/s (295 ft/s)

Oil viscosity: ISO VG up to 68

## Materials

Seal face: Silicon carbide / Carbon

Seat: Silicon carbide

Secondary seals: FKM

Metal parts: 1.4006 or other stainless steels

## Item Description

1	Seat, rotating
2	Seal face, stationary
3	Face housing
6	Spring
7	Shaft sleeve
13	Housing
A	Oil IN
B	Oil OUT

# EBU800

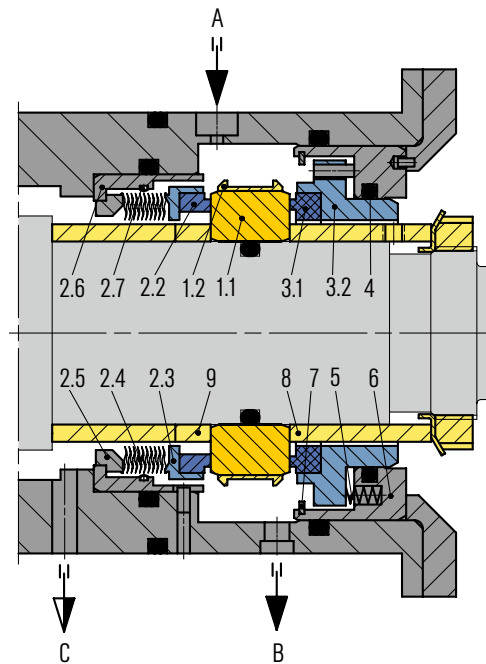

EBU800 double seal as used in dry screw compressors.

**Oil-lubricated** seal for screw compressors. This special shaft seal is characterized by its straightforward structure, compact length and quiet running even under changing pressure conditions. It also seals reliably at both high and low temperatures.

**Features**

- Double seal
- Balanced
- Bi-directional
- Stationary bellows (process side)
- Multiple springs (bearing side)
- Shrink-fit seat
- Double-pressure balanced

**Advantages**

- Suitable for high sliding velocities
- Seal does not open if oil pressure drops
- Rugged seat with bandage ensures reliable operation
- Compact design with few sealing components

**Operating range**

Shaft diameter:  $d = \dots 220 \text{ mm (8.66")}$   
 Pressure:  $(p_2-p_1) = \dots 5 \text{ bar (73 PSI)}$   
 Sliding velocity:  $v_0 = 90 \text{ m/s (295 ft/s)}$

**Materials**

Bellows: AM350, Inconel® 718, Hastelloy®-C  
 Seal face: Special SiC, high-density carbon graphite  
 Seat: Silicon carbide  
 Secondary seals: FKM (bearing side)  
 Metal parts: 1.4301, Carpenter® 42, Inconel® 718, Hastelloy®-C

**Item**

**Description**

1.1	Seat
1.2, 2.3, 3.2	Retainer
2.2, 3.1	Seal face
2.4	Bellows
2.5	Adapter
4	O-ring
5	Spring
2.6, 6	Housing
2.7	Damper
7	Retaining ring
8	Sleeve
9	Spacer
A	Oil IN
B	Oil OUT
C	Drain



# EagleBurgmann separation seals



EagleBurgmann has exactly the right seal for safely and reliably sealing the bearing oil of compressors. We supply carbon ring seals (aerostatic and aerodynamic lift-off) and our gas-lubricated and non-contacting CobraSeal. All separation seals are short and compact and can easily be integrated into the main seal housing or retrofitted as a separate unit.

**CSE - segmented carbon rings,  
non-contacting**

**CSR - carbon rings, lift-off**

**CobraSeal - gas-lubricated,  
non-contacting**

# CSE

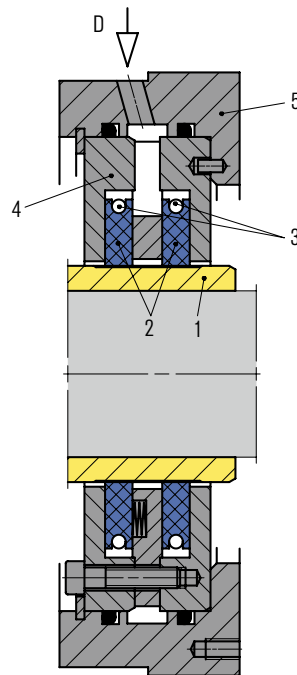

The service-proven bearing oil seal with low gas consumption. Non contact type carbon rings are segmented rings held together by a garter spring at the outer diameter. A defined minimum radial gap ensures contact-free operation. Robust design and reliable operation provide secure oil sealing even under extreme conditions.

### Features

- Non-contact type separation seal
- Gas-lubricated
- Bi-directional
- Ready-to-fit cartridge unit
- Equipped with Espey type WKA400 carbon rings

### Advantages

- Low leakage
- Slow roll capability
- Insensitive to dry nitrogen

### Operating range

Shaft diameter: 38 ... 390 mm (1.50" ... 15.35")  
 Design pressure:  $p = \dots 10 \text{ bar (145 PSI)}$   
 Operating pressure:  $p = 0.1 \dots 0.2 \text{ bar (1.45 ... 2.90 PSI)}$   
 Temperature:  $t = -20 \text{ }^\circ\text{C} \dots +120 \text{ }^\circ\text{C} (-4 \text{ }^\circ\text{F} \dots +248 \text{ }^\circ\text{F})$   
 Sliding velocity:  $v_g = 0 \dots 200 \text{ m/s (656 ft/s)}$   
 Dew point: No limitation  
 Project-specific special designs possible

### Materials

Seal face: Carbon graphite impregnated  
 Secondary seals: FKM  
 Shaft sleeve: Stainless steel TC-coated  
 Metal parts: 1.4006 or other stainless steels

### Certificates

- NACE

### Item Description

- |   |  |
|---|--|
| 1 | Shaft sleeve                                     |
| 2 | Segmented carbon ring                            |
| 3 | Garter spring                                    |
| 4 | Housing for standardized sub-cartridge           |
| 5 | Housing (size adapted to the installation space) |
| D | Separation gas                                   |

# CSR

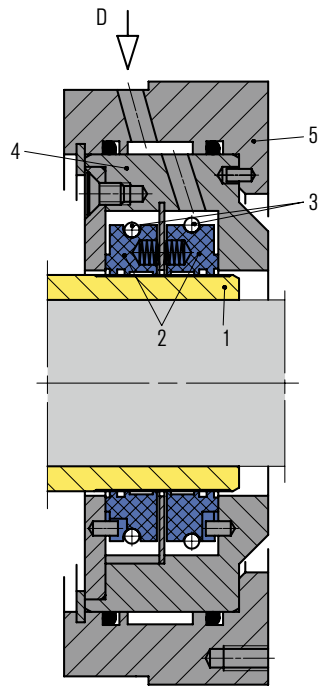

Lift-off type carbon ring seals feature very low gas consumption for both dynamic and static operation modes. In static operation the carbon segments will contact the shaft, reducing gas consumption to a minimum. In dynamic operation, the profiled inner surface of the segmented ring will ensure aerodynamic lift-off at circumferential speeds >10 m/s (33 ft/s). The segmented carbon rings float on a very thin gas film of few  $\mu\text{m}$ .

## Features

- Lift-off type separation seal
- Gas-lubricated
- Bi-directional
- Ready-to-fit cartridge unit

## Advantages

- Very low leakage
- No increased leakage in static operation

## Operating range

Shaft diameter: 38 ... 360 mm (1.50" ... 14.17")  
 Design pressure:  $p = 0.5 \dots 10 \text{ bar}$  (7.25 ... 145 PSI)  
 Operating pressure:  $p = 0.5 \dots 0.8 \text{ bar}$  (7.25 ... 11.60 PSI)  
 Temperature:  $t = -20 \text{ }^\circ\text{C} \dots +150 \text{ }^\circ\text{C}$  (-4  $^\circ\text{F} \dots +302 \text{ }^\circ\text{F}$ )  
 Sliding velocity:  $v_g = 10 \dots 140 \text{ m/s}$  (33 ... 459 ft/s)  
 Dew point:  $t = -50 \text{ }^\circ\text{C} \dots +20 \text{ }^\circ\text{C}$  (-58  $^\circ\text{F} \dots +68 \text{ }^\circ\text{F}$ )

## Materials

Seal face: Carbon graphite impregnated  
 Secondary seals: FKM  
 Shaft sleeve: Stainless steel TC-coated  
 Metal parts: 1.4006 or other stainless steels

## Certificates

- NACE

## Item Description

- |   |  |
|---|--|
| 1 | Shaft sleeve                                     |
| 2 | Segmented carbon ring                            |
| 3 | Garter spring                                    |
| 4 | Housing for standardized sub-cartridge           |
| 5 | Housing (size adapted to the installation space) |
| D | Separation gas                                   |

## CSR version for dry nitrogen

The CSR separation seal is also available for operation with very dry nitrogen with a dew point of at least  $-90 \text{ }^\circ\text{C}$  ( $-130 \text{ }^\circ\text{F}$ ). Newly developed carbon ring materials ensure smooth operation even when the CSR is supplied with very pure nitrogen, from e.g. cryogenic production. The reliability of the system can be increased significantly as a result.

# CobaSeal

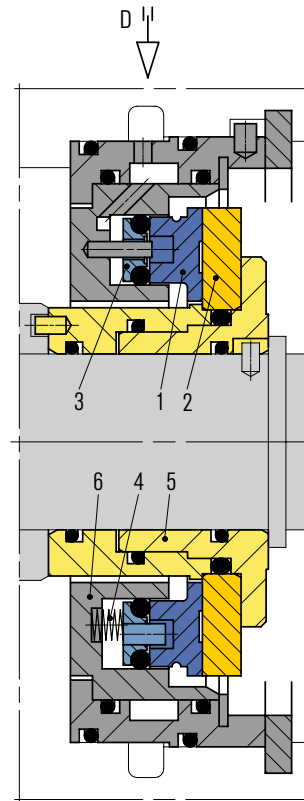
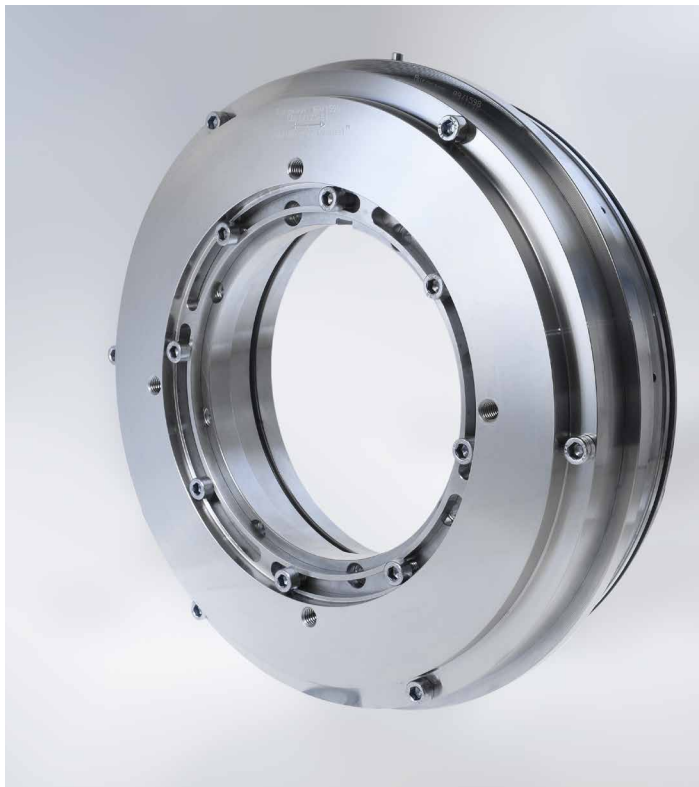

Item	Description
1	Seal face, stationary
2	Seat, rotating
3	Thrust ring
4	Spring
5	Shaft sleeve and seat retainer
6	Housing (size adapted to the installation space)
D	Separation gas

Since it was launched on the market, this innovative sealing solution has proven its worth worldwide in both first fit and retrofit applications. It consists of a rotating seat made of ductile material and a stationary, spring-loaded seal face. The separation gas is routed through axial holes in the stationary seal ring into the middle of the sliding face. It is then divided in the sealing gap into two leakage flows which are routed to the inner and outer diameters of the seal face.

### Features

- Gas-lubricated
- Bi-directional
- Ready-to-fit cartridge unit
- Self-cleaning 3D gas grooves
- Aerostatic and aerodynamic lift-off

### Advantages

- Extremely low leakage
- Double arranged (coaxial) dry gas seal with just one pair of seal faces
- Insensitive to oil contamination due to its special design
- Wear-free, non-contacting operation in all conditions
- Insensitive to radial vibrations due to axial sealing gap
- Slow-roll or turning operation capable (static lift-off)
- No limits regarding dew point of separation gas (silicon carbide instead of carbon)
- Lower N<sub>2</sub> consumption than any other system
- N<sub>2</sub> can be switched off during standstill – the gap will close and still provide the best oil sealing performance.
- Best in class oil sealing by extremely small sealing gap and sling effect of rotating ring

### Certificates

- NACE

### Operating range

Shaft diameter: 29.5 ... 210 mm (1.16" ... 8.27")  
 Pressure (vent): p = 0 ... 15 bar (0 ... 218 PSI)  
 Operating pressure: p = 2.7 bar (39.16 PSI)  
 Temperature: t = -20 °C ... +150 °C (-4 °F ... +302 °F)  
 Sliding velocity: v<sub>g</sub> = 0 ... 150 m/s (0 ... 492 ft/s)  
 Dew point: No limitation

### Materials

Seal face: Silicon carbide\*  
 Seat: ductile stainless steel\*  
 Secondary seals: FKM  
 Metal parts: 1.4006  
 \* With special EagleBurgmann high performance iDLC (in situ diamond-like carbon) coating

### Single DGS + CobaSeal = Tandem seal

The CobaSeal is not just an excellent separation seal. It can also be used as a true back-up seal for greater safety. A DGS-CobaSeal tandem arrangement can be operated at sealing pressures up to 20 bar (290 PSI). It does not need an intermediate labyrinth with N<sub>2</sub> supply and existing single seals can be simply retrofitted, thus benefitting from increased operational safety. The single DGS + CobaSeal combination is also shorter than conventional tandem seals with separation seal and costs can be saved on the gas supply system in low pressure applications.

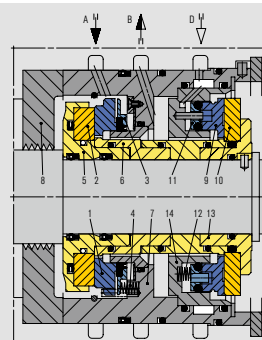

Item	Description
1, 9	Seal face, stationary
2, 10	Seat, rotating
3, 11	Thrust ring
4, 12	Spring
5, 13	Shaft sleeve
6	Adapter sleeve
7, 14	Housing
8	Labyrinth

# EagleBurgmann gas supply systems



EagleBurgmann gas supply systems are designed for the operating conditions of the compressor. Emphasis is placed on optimally fulfilling the requirement of the gas seal, which eliminates the possible damage risks such as a build-up of moisture in the gas. This allows the seals to operate safely and continuously, simultaneously increasing the compressor availability.

Additional modules, a complete gas conditioning skid and the EagleBurgmann RoTechBooster can be combined to prevent critical operating conditions for the seal, such as when the compressor is stopped.

**SMS – seal management systems and gas conditioning skids**  
**RoTechBooster – continuous gas supply and pressurization**

# SMS



The EagleBurgmann SMS is a customizable system based on four modules. It is used to continuously supply and monitor Dry Gas Seals.

### Description of functions

(Example: supplying a tandem DGS, see scheme on page 6)

To avoid contamination of the seal, gas is generally taken from a higher compression stage, conditioned, filtered and output as clean flushing gas to the gas seal on the process side. Any leakage via the first gas seal stage is dissipated to the flare. To prevent bearing oil contaminating of the gas seal, there is a separation seal in the form of a nitrogen or air barrier (separation gas) between the bearing and the gas seal.

### Primary seal gas line or buffer gas line

- Supplying with filtered and dry flushing gas
- Monitoring and regulating the flow rate and/or the (differential) pressure
- Monitoring the gas filter
- For double seals, process gas is generally injected in front of the seal as a gas buffer. The actual seal is supplied with nitrogen.

### Secondary seal gas line

- Supplying with filtered Nitrogen
- Monitoring and regulating the flow rate and/or the (differential) pressure
- Monitoring the gas filter

### (Primary) vent line

- Monitoring of the leakage from the seal and outputting an alarm when the expected leakage is exceeded
- Ensuring that the leakage is dissipated to a flare or flare system

### Separation gas line

- Supplying and monitoring the separation seal with nitrogen or air
- Monitoring and regulating the flow rate and/or the (differential) pressure

### Advantages

- Reliable operation by supplying the seal with filtered and dry flushing gas, barrier gas and separation gas
- Condition of the filters, control valves, instrumentation and nitrogen and flushing gas sources are checked at all times
- Constant monitoring for leakage and seal function.
- Individually adaptable to suit operating conditions and safety requirements
- All current industrial standards, such as API and special operator requirements, can be fulfilled
- Gas supply system (SMS) available with additional gas conditioning skid

Gas conditioning skid

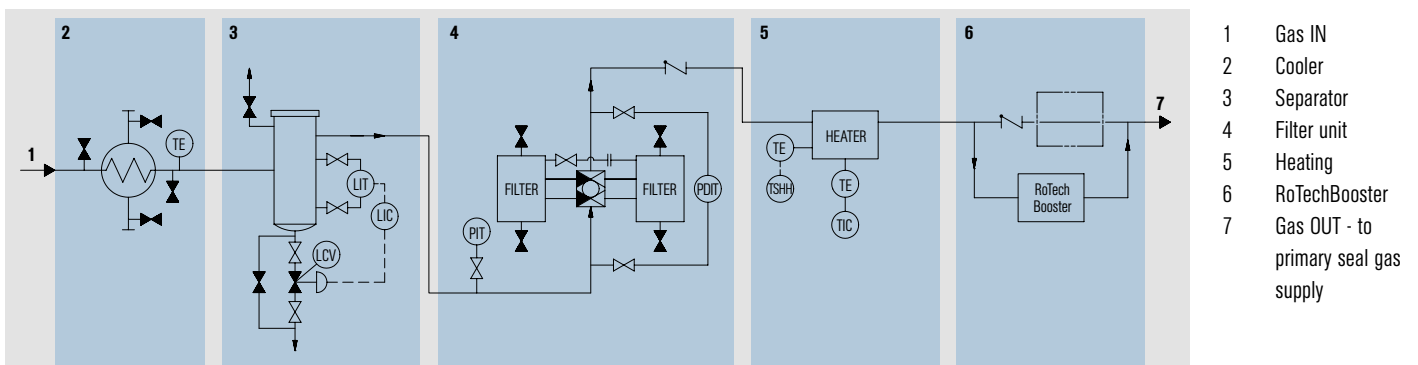

# RoTechBooster

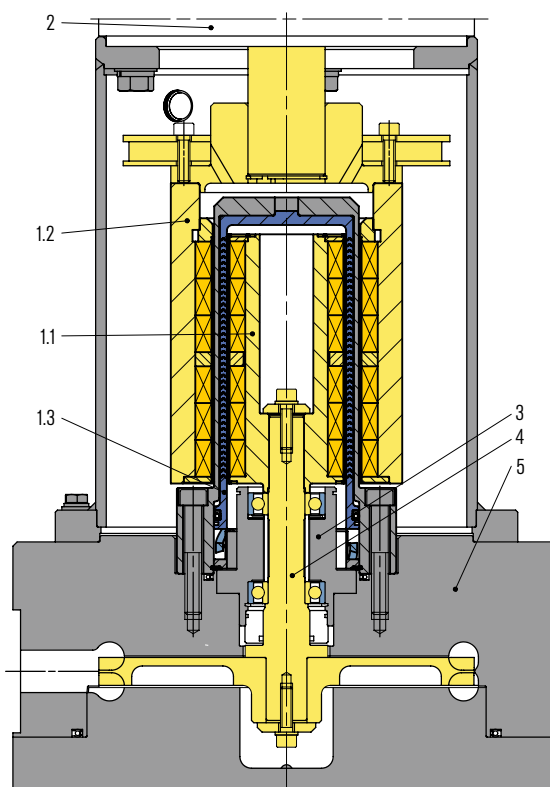

The RoTechBooster ensures a reliable and consistent flow of gas, even during fluctuating operating conditions. Gas seals can thus be reliably supplied with clean and dry gas in any situation. No rubbing shafts or seals and no sliding parts means fewer parts to maintain. Centrifugal solutions are known to be very reliable and eliminate pulsation in the gas flow.

## Operating range

Pressure:  $p = 0 \dots 360 \text{ bar (5,221 PSI)}$   
 Temperature:  $t = -40 \text{ °C} \dots +200 \text{ °C (-40 °F} \dots +392 \text{ °F)}$   
 Motor size: 5.5 kW ... 15 kW  
 Diameter: 355 mm ... 560 mm (14" ... 22")  
 Higher pressure or temperature versions on request.

## Item Description

Item	Description
1.1	Inner rotor
1.2	Outer rotor
1.3	Can
2	Motor
3	Bearing cartridge
4	Impeller
5	Pressure housing

## Features

- Centrifugal design – high reliability and availability
- High efficiency magnetic coupling: Eddy currents reduced by 95%, lower power consumption, reduced heat generation.
- Simple set up, virtually maintenance-free
- No oils required for lubrication
- ATEX certification available on request
- Available in different sizes, depending on requirements.
- Easy to operate

## Advantages

- No limits on operating times
- Service life 3-4 times longer than the previously available solutions.
- Totally gas tight without leakage to the atmosphere, increasing safety for the environment and personnel as a result.



EagleBurgmann gas conditioning skid with integrated RoTechBooster.

## Best practice: Successful sealing solutions for our customers.



The Sulzer ethane pipeline pumps in the Enterprise Pipeline in the USA have been equipped with EagleBurgmann type **DF-DGS6/98-ZT1-U** gas seals with DiamondFace coating since July 2011. Much longer operating periods can be achieved with these compared to the liquid-lubricated seals originally used. Design conditions:  $p = 50 \text{ barg (725 PSIG)}$ ,  $t = -30 \text{ °C ... +200 °C (-22 °F ... +392 °F)}$ ,  $n = 3,600 \text{ min}^{-1}$ .



There are several **PDGS10/200-ZT9-L/R** gas seals integrated into centrifugal compressors from Shenyang Blowers in the West-East gas pipeline II (WEPP) that runs right across the whole of China. The pipeline is operated by Petrochina. Design conditions:  $p = 120 \text{ barg (1,740 PSIG)}$ ,  $t = -50 \text{ °C ... +230 °C (-58 °F ... +446 °F)}$ ,  $n = 5,250 \text{ min}^{-1}$ .



The Al-Shaheen oil platform operated by Maersk Oil in the Middle East has been successfully using CobraSeal separation seals since 2012. The EagleBurgmann **CBS10/140-E2-U** are installed in Siemens centrifugal compressors. Design conditions:  $p = 13 \text{ barg (189 PSIG)}$ ,  $t = -20 \text{ °C ... +40 °C (-4 °F ... +104 °F)}$ ,  $n = 13,619 \text{ min}^{-1}$ .



EagleBurgmann supplied Petrobras with **PDGS50/135-ZT1-L/R** seals for gas injection in the Lula oilfield in Brazil. They are designed for high pressures up to 428 barg (6,206 PSIG) and reliably seal Nuovo Pignone centrifugal compressors. Design conditions:  $t = -50 \text{ °C ... +230 °C (-58 °F ... +446 °F)}$ ,  $n = 13,844 \text{ min}^{-1}$ .



The largest gas seal to date - an EagleBurgmann **PDGS10/390-ZT4-L** with a shaft diameter of 350 mm (13.78") - has been in use in the Wuhan Iron & Steel works in China since 2009. It is installed in a Nuovo Pignone centrifugal compressor. The seal performs in the  $-50 \text{ °C ... +250 °C (-58 °F ... +482 °F)}$  temperature range. Design conditions:  $p = 50 \text{ barg (725 PSIG)}$ ,  $n = 3,000 \text{ min}^{-1}$ .

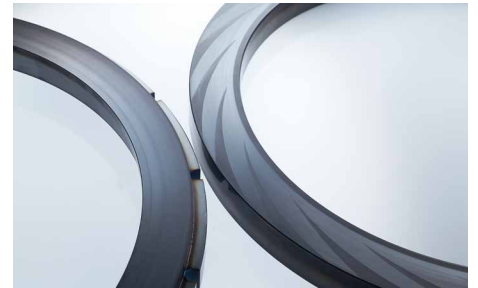

For Petrochina, EagleBurgmann has supplied several **PDGS10/210-ZT5-U** gas seals with DiamondFace coating. These are installed in Siemens centrifugal compressors. The extremely hard and wear-resistant coating provides optimal protection under operating conditions in which the sliding faces come into contact. Design conditions:  $p = 160 \text{ barg (2,320 PSIG)}$ ,  $t = -50 \text{ °C ... +230 °C (-58 °F ... +446 °F)}$ ,  $n = 4,782 \text{ min}^{-1}$ .





An EagleBurgmann **PDGS** designed for extremely low temperatures was installed in close collaboration with Atlas Copco in a compressor on the LNG carrier "Jamal". Design conditions:  $p = 50 \text{ barg}$  (725 PSIG),  $t = -170 \text{ }^\circ\text{C} \dots +150 \text{ }^\circ\text{C}$  (-274 °F ... +302 °F),  $n = 23,000 \text{ min}^{-1}$ .



There is an EagleBurgmann **PDGS10/78-E3-U** in operation in a Cryostar compander at Qatar Gas in Qatar. This is specially designed for low temperature applications. Design conditions:  $p = 52 \text{ barg}$  (754 PSIG),  $t = -196 \text{ }^\circ\text{C} \dots +230 \text{ }^\circ\text{C}$  (-321 °F ... +446 °F),  $n = 22,100 \text{ min}^{-1}$ .

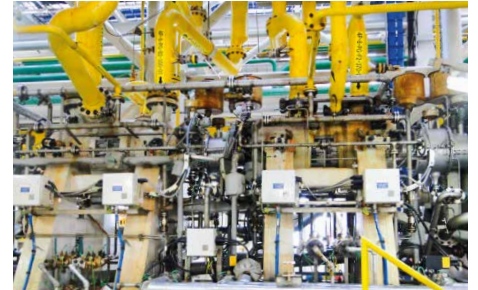

EagleBurgmann high pressure **PDGS6/140-ZT1-L/R** seals have been installed on the FPSO ships operated by Petrobras in the Lula oilfield off the Brazilian coast since 2011. The medium is natural gas with a high  $\text{CO}_2$  content. Design conditions:  $p = 335 \text{ barg}$  (4,858 PSIG),  $t = -50 \text{ }^\circ\text{C} \dots +230 \text{ }^\circ\text{C}$  (-58 °F ... +446 °F),  $n = 12,076 \text{ min}^{-1}$ .



EagleBurgmann type **225H-120** and **225L-120 RoTechBoosters** with 11 and 15 kW motors have been in use at pressures up to 120 bar (1,740 PSI) in the compressor stations of the 3,800 km long US/ Canadian Alliance pipeline since July 2012. They replaced the previously used piston boosters, which caused maintenance problems and downtimes. Everything has been running without problems since the change.



EagleBurgmann **PDGS5/145-ZT1-U** gas seals are in use in RAG Austria's natural gas storage facility in Haidach, Austria. They reliably seal compressors from MAN Diesel & Turbo which are used to compress and remove the gas. Design conditions:  $p = 250 \text{ barg}$  (3,625 PSIG),  $t = -50 \text{ }^\circ\text{C} \dots +230 \text{ }^\circ\text{C}$  (-58 °F ... +446 °F),  $n = 14,457 \text{ min}^{-1}$ .



At Gasco Abu Dhabi, EagleBurgmann **MDGS1/130-D1-U** gas seals are used in screw compressors from MAN Diesel & Turbo. The seal takes up very little space radially and is extremely wear-resistant due to the ductile rotating seal ring with its high-performance coating. Design conditions:  $p = 15 \text{ barg}$  (218 PSIG),  $t = -20 \text{ }^\circ\text{C} \dots +200 \text{ }^\circ\text{C}$  (-4 °F ... +392 °F),  $n = 10,568 \text{ min}^{-1}$ .

# Worldwide and always available: EagleBurgmann TotalSealCare service for compressor seals.



A network of technology, competence and service centers dedicated to compressor seals covers all regions of the world. This allows us to respond quickly and efficiently to customer requirements.

- We have two technology centers operating at the global level in Germany (Eurasburg) and Japan (Niigata).
- There are five centers of competence in USA (Houston), Brazil (Sao Paulo), UAE (Dubai) India (Pune) and China (Dalian), all of which are equipped with testing facilities for dynamic test runs.
- We have further service centers in Mexico (Mexico City), South Africa (Edenvale) and Russia (Zavolzhe).

- Dry Gas Seals production, Engineering
- Seal Management Systems production, Engineering
- Service Centers (testing, repairs)
- Compressor seals experts
- Sales support, Application engineering, Product management, Engineering lead

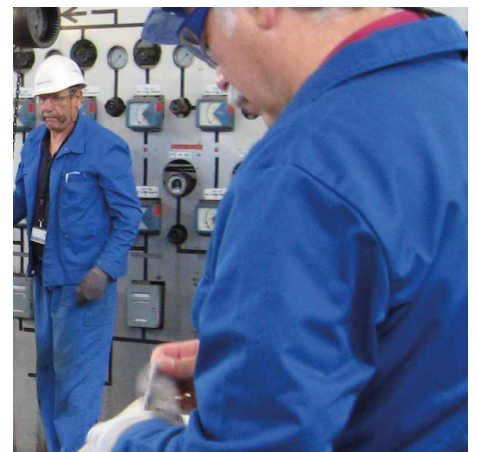



## Our compressor seal services

Optimized services are major contributors to making sure that plants run without interruption - and that doesn't just start with maintenance. With TotalSealCare, our modular service concept, we are able to cover all individual service requirements very flexibly.

Our trained and experienced service engineers are able to perform all tasks, either in our many service centers around the world or on the customer's own premises. And naturally they have the appropriate qualifications (e.g. S2S certificate).

We offer everything that ensures the best service, broken down into individual modules and tailored programs. From full servicing of all installed seals, via stock management and right through to engineering, training and electronic documentation.

Advantages: reduced costs, increased plant availability and greater reliability. And best of all, you only choose the services that you actually need. As the services can be individually combined, with TotalSealCare, you can put together a service package that totally meets your requirements and expectations. Tailored to you and unique in its flexibility and transparency. Some examples:

## Consulting & engineering

E.g. advice on applications, inventory of all sealing systems in use, standardization concepts, seal upgrades, bad actor analysis and analysis of critical applications.

## On-site service, upgrades and retrofits

E.g. seal assembly/disassembly, inspection, maintenance, repair, replacement of spare parts for seals and gas supply systems. Upgrade from oil-lubricated to gas-lubricated sealing systems.

## Technical analysis & support, troubleshooting

E.g. inspection and assessment of seals, systems and on-site situation. Allocation of a cross-functional team of experts for investigations, recommendations and detailed root cause analysis, including chemical analysis, plotting of dew point curves.

## Service agreements

Agreements matched to customer requirements ensure that individual seals or entire systems continue to operate without interruption. For example, a contract concluded with a French operator includes keeping a stock of different compressor seals for the customer's multiple locations, rapid delivery of replacement seals and repairs made within set times.

Algeria · Angola · Argentina · **Australia** · **Austria** · Bahrain · Bangladesh · Belarus · **Belgium** · Botswana · **Brazil** · Bulgaria · Cameroon · **Canada** · Chile · **China** · **Colombia** · Congo · Cyprus · **Czech Republic** · **Denmark** · **Ecuador** · Egypt · Estonia · Finland · **France** · Gabon · **Germany** · Ghana · **Great Britain** · Greece · **Hungary** · **India** · **Indonesia** · Iraq · Ireland · Israel · **Italy** · Ivory Coast · **Japan** · Jordan · Kazakhstan · Kenya · **Korea** · Kuwait · Latvia · Lebanon · Libya · Lithuania · Madagascar · **Malaysia** · Mauritius · **Mexico** · Morocco · Myanmar · Namibia · **Netherlands** · **New Zealand** · Nigeria · **Norway** · Oman · Pakistan · Paraguay · Peru · **Philippines** · **Poland** · Qatar · Romania · **Russia** · **Saudi Arabia** · Serbia · **Singapore** · Slovak Republic · Slovenia · **South Africa** · **Spain** · Sudan · **Sweden** · **Switzerland** · **Taiwan** · **Thailand** · Trinidad and Tobago · Tunisia · **Turkey** · Ukraine · **United Arab Emirates** · Uruguay · **USA** · **Venezuela** · **Vietnam** · Yemen · Zambia · Zimbabwe · [www.eagleburgmann.com/world](http://www.eagleburgmann.com/world)



K-KDE / E2 / 3.000 / 07.15 / 9.71 © EagleBurgmann Group Marketing, Germany

EagleBurgmann is one of the internationally leading companies for industrial sealing technology. Our products are used everywhere where safety and reliability are important: in the oil and gas industry, refining technology, the petrochemical, chemical and pharmaceutical industries, food processing, power, water, mining, pulp & paper, aerospace and many other spheres. Every day, more than 6,000 employees contribute their ideas, solutions and commitment towards ensuring that customers all over the world can rely on our seals. Our modular TotalSealCare service underlines our strong customer orientation and offers tailor-made services for every application.

[eagleburgmann.com](http://eagleburgmann.com)

[info@eagleburgmann.com](mailto:info@eagleburgmann.com)

**EagleBurgmann®**

Rely on excellence